

## **AN APPROACH TO ANALYSING INTERFACE UNCERTAINTY USING THE CONTACT AND CHANNEL MODEL**

**Freund, Tillmann; Kloberdanz, Hermann; Lotz, Julian; Würtenberger, Jan**  
TU Darmstadt, Germany

### **Abstract**

The authors give a short introduction to uncertainty and introduce uncertainty terms for modular systems: Interface Uncertainty and Configuration Uncertainty. In order to control these forms of uncertainty a particular robust design methodology is needed that consists of models, methods and tools to describe, analyse, assess and finally control uncertainty. In this context, the authors provide a characterisation of what interfaces are and how they can be described through adequate properties, functions and other characteristics.

To analyse interfaces, the Contact and Channel Model is adapted to consider the main Working Surface Pairs in Working principle Sketches or rather to simplify existing interfaces aiming at a better understanding for the designer in order to make a design more robust.

Uncertainty and Interfaces, both represented in adequate models, are then brought together in one single model that can now be used to consistently describe uncertainty in the whole product lifecycle.

**Keywords:** Uncertainty, Robust Design, Contact and Channel Model, Process modelling, Design Clarity

### **Contact:**

Tillmann Freund  
TU Darmstadt  
Product Development and Maschine Elements  
Germany  
freund@pmd.tu-darmstadt.de

Please cite this paper as:

Surnames, Initials: *Title of paper*. In: Proceedings of the 20th International Conference on Engineering Design (ICED15), Vol. nn: Title of Volume, Milan, Italy, 27.-30.07.2015

# 1 INTRODUCTION

Many strategies are available to reduce the negative ecological effects that occur during a product life cycle, such as reducing mass to lower energy consumption during product application. Although the phases of material processing and production generally do not contain many variations, the application phase is highly transient due to changes in user needs and deviations in environmental conditions. Modular system designs are one way to already anticipate changes in the application phase as quickly as in the development phase. Modular product architectures therefore enable adaptation to variability. Additionally, a modular product structure can be implemented to react easily to the effects of aging and wear, reducing the amount of waste and minimizing ecological impact.

There are disadvantages that have to be taken into account, as in *Feldhusen and Grote (2013)*. Increasing modularity normally leads to an increasing number of interfaces. *Garud and Kuramaswamy (1996)* state: *As the number of interfaces increases, the possibility of performance losses at the interfaces also increases. Furthermore, excessive modularization increases the complexity of the design.* *Braha et al (2006)* declare: *As systems become more complex, the design of interfaces between parts occupies increasing attention.* As a state where not all of the relations between components and their behaviours can be determined, complexity is closely related to uncertainty, which occurs, according to *Hanselka and Platz (2012)*, if process properties cannot be determined. Therefore, it is assumed that interfaces increase system uncertainty. Interfaces are often standardized and can sometimes compromise functionality as they are not designed to fulfil one particular purpose but must fit all uses. Interfaces are normally more sensitive to disturbance and uncertainty due to tolerances during production. Every “face” brings new tolerances into the system, which link to form tolerance chains and can extensively affect product behaviour. While many system modularization methods are available, there are only few that explicitly support interface design. *Ebro et al. (2012)* propose *Design for clarity* to obtain a correctly constrained system at the interface level, which is a precondition for robustness. Typical interface design problems are identified and can be controlled using appropriate measures. Although this approach seems to be an applicable procedure, there is still a need for systematic definition, description and representation of interfaces in product development models to use them as a basis for designing for robustness. This paper contributes to closing this gap, combining product and process perspectives. The main hypothesis is that uncertainty in interfaces can be controlled if uncertainty in interface properties can be addressed in life cycle processes and their variations.

This, firstly, requires adequate models, derived in the following sections.

Although the background and motivation focus on interfaces in modular systems, this paper aims for a generalised understanding of interfaces.

## 2 PARTICULAR UNCERTAINTY OF MODULAR PRODUCTS

### 2.1 Uncertainty

To understand the particular uncertainty of modular products, first uncertainty in general has to be specified and defined. *Collaborative Research Centre SFB 805* at the *Technische Universität Darmstadt* states that uncertainty occurs in processes if process properties cannot be determined (*Hanselka and Platz, 2012*). *Eifler et al. (2011)* introduce a process model that differentiates between uncertain influence parameters occurring in processes (Figure 2). The process itself can be seen as a time-dependant transformation of an operand, describable through properties, from an initial state to a final state.

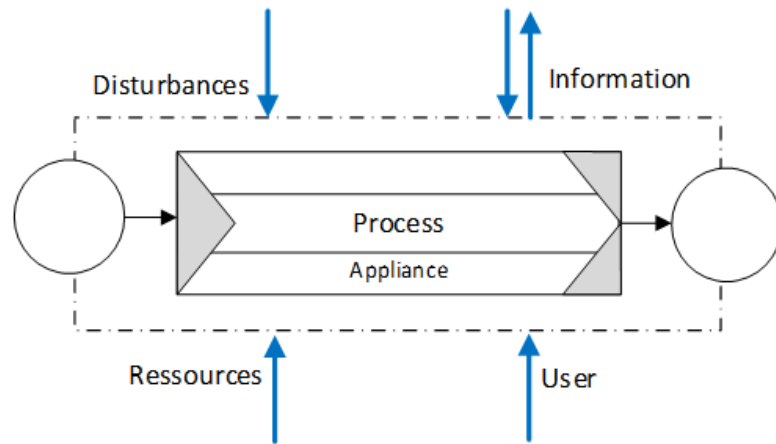

Figure 1. SFB 805 process model (Eifler et al., 2011).

An academic example is used to better illustrate this relation. A simple bar may be loaded with a force  $F$  during application (Figure 3). The resulting stress level in the bar can be calculated using the formula

$$\sigma = \frac{F}{A} = \frac{F}{\pi \cdot r^2} . \text{ Condition: } \sigma \cdot S \leq \sigma_R. \quad (1)$$

The stress level needs to be lower than the admissible tensile stress  $\sigma_R$ , when including safety factor  $S$ .  $\sigma_R$  depends on the material used. As long as the condition formulated above is fulfilled, the bar will not fail. All parameters are deterministic values. This is how engineers calculate parts in their everyday work.

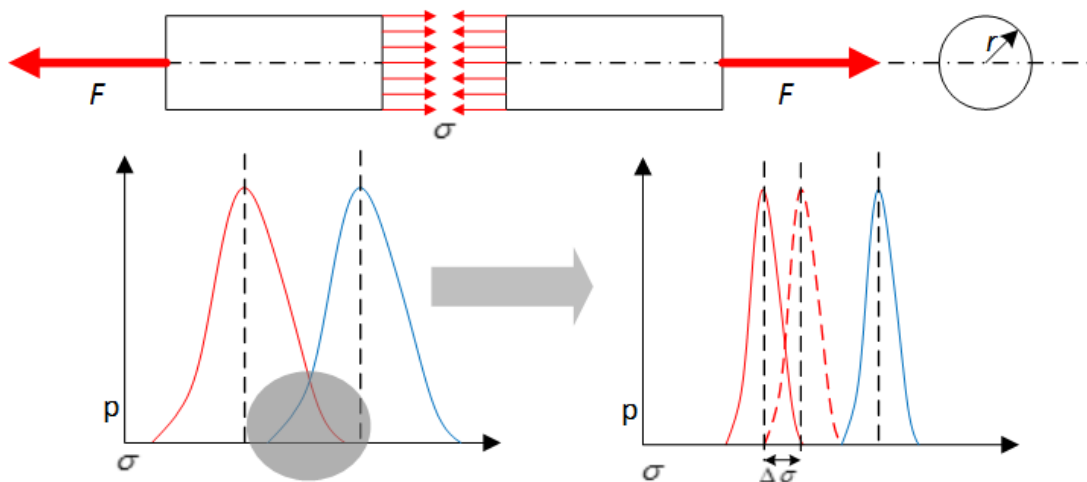

Figure 2. Example of a beam under uncertain load and the resulting tensile stress level compared to admissible tensile stress

In reality, the parameters are not deterministic; application process forces are distributed parameters and geometric parameters that result from manufacturing processes can differ in measures and form. Assuming that tensile stress and maximum tensile strength are distributed and can be represented through the probabilistic density functions in Figure 3, the bar will not fail as long as there is no overlap between the distributions. This shows that the safety factor is a common way to control uncertainty in design parameters, i.e. the safety factor is an uncertainty factor. In order to achieve improvements in energy consumption, for example, in airplane design, the uncertainty in the parameters has to be reduced to fully use the capacity of the materials while at the same time minimizing risks (Figure 3). To support this methodically, Engelhardt (2013) and Eifler (2014) provide tools to identify and assess uncertainty in all life phases (processes) of the product. Engelhardt (2013) classifies uncertainty into three main categories (Figure 4):

- **Unknown Uncertainty**  
Unknown Uncertainty occurs if the effect or the relation between parameters is unknown and therefore has to be assumed. This type of uncertainty often occurs in early development phases of new products and is related to a lack of information.
- **Estimated Uncertainty**  
This describes a very common state of information in engineering. Based on a generally known physical effect, an interval is used to describe a design parameter or a relation.
- **Stochastic Uncertainty**  
Stochastic Uncertainty is the lowest instance of uncertainty and cannot be further reduced. It requires an adequate knowledge about the design parameter or relation as a minimum.

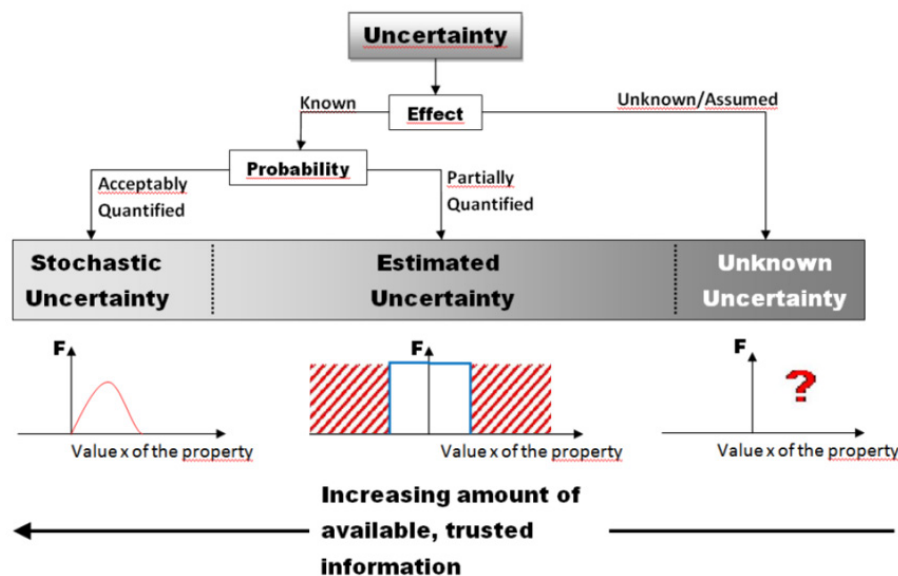

Figure 3. SFB 805 uncertainty model (Engelhardt, 2013)

## 2.2 Uncertainty of modular Products

Aside from the instances of uncertainty and where it occurs, it is useful to classify uncertainty into purposeful types, for example, uncertainty related to specific design strategies, to assess whether a particular solution fits with the requirements related to uncertain parameters. In modular products, there are two types of uncertainty:

- **Interface Uncertainty**  
Because of the intended variability of modular products, interfaces are needed that would not have been necessary in an individual product. These interfaces often cannot be functionally optimized to one specific use due to standardisation. Additionally, tolerances related to manufacturing superpose each other, building tolerance chains. Another uncertainty factor in interfaces is influences resulting from disturbances.
- **Configuration Uncertainty**  
Uncertainty in modular systems through configuration occurs because of the unknown and/or unintended interactions of a specific combination of modules in a variant. These interactions happen through interfaces and through influences without an intended interface, such as radiation or heat dissipation.

## 3 INTERFACE REPRESENTATION

### 3.1 Characterising interfaces

As in Engelhardt (2013), uncertainty has to be described, identified and assessed to be controlled through purposeful measures. First, an exact understanding of an interface is required. To achieve this, literature research was conducted. There are some definitions within the context of modular systems available: Stone et al. (1998) state: *The interface boundaries defined are physical connections between module and product.* Schilling (2000) declares: *The components are able to connect, interact, or*

exchange resources (such as energy or data) in some way, by adhering to a standardized interface. Feldhusen and Grote (2013) refer to a definition from Ulrich (1995): Following this definition, interacting components are connected by types of physical interfaces. Most of the more detailed definitions are used in the context of the *Contact & Channel Model (C&CM)*. This context is quite useful for controlling uncertainty because of the explicit relation between functional and physical parts. All authors (Birkhofer, Albers, Matthiesen, Ersoy, Frei) agree that an interaction between parts or bodies requires contact of **Working Surfaces**, the **Working Surface Pair (WSP)** (Working surface couples, working functions). Every **transmission of Energy, Material and Signals** is realized through these WSPs. The structure in between is the **working structure (WS)** (working body, channel and support structures). While *Matthiesen* (2002) and *Albers* (2004) define only the WFP as an interface, in this paper this general definition is derived:

*An interface consists of the working surfaces and working bodies that transmit energy, material and signal flows. The interface can be described through its properties.*

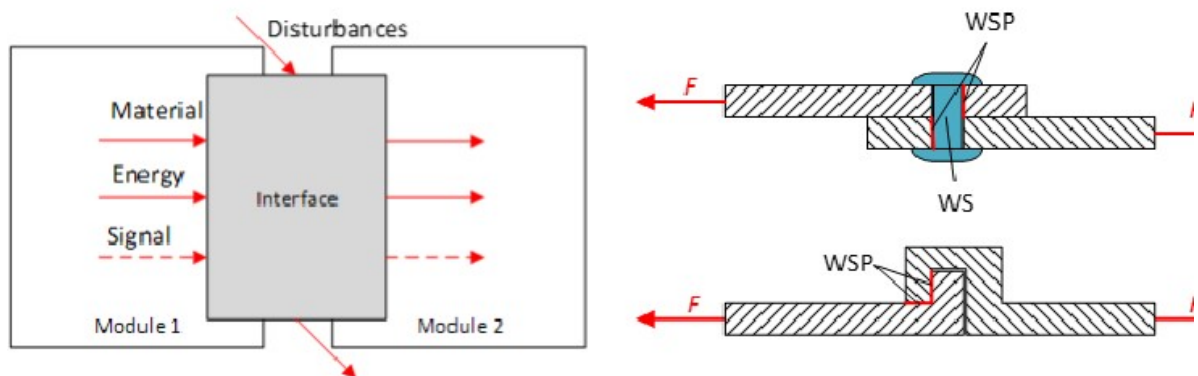

Figure 4. Interface Model (left) and examples of an intermediate and a mediate interface to illustrate the definition of interfaces (right)

This definition includes a general description of what the interface does, how the interaction is realised and how it can be described. It includes interfaces, as in *Mathiesen* and *Albers*, that are the most granular interfaces, which can be seen as *elementary interfaces*. This is illustrated in Figure 6 on the right side. A bolt connection between two sheet metal pieces is an interface (2 WSP, 1 WS, mediate connection), as is the form fit (2 WSP, intermediate connection) as well.

Table 1 contains all characteristics that were found in literature that describe interfaces. Most of them are properties, but some are functions. Assuming that all characteristics were found, uncertainty resulting from lifecycle processes can now be addressed in the corresponding interface properties.

This step is shown in Section 4.

Table 1. Characterisation of interfaces

Design Working surface	
<ul style="list-style-type: none"> <li>• Dimensional-</li> <li>• Form-</li> <li>• Position tolerances</li> </ul>	
Design Working Structure	Material Working Structure
<ul style="list-style-type: none"> <li>• Dimension</li> <li>• Position</li> </ul>	<ul style="list-style-type: none"> <li>• Young's Modulus</li> <li>• Admissible Stress</li> <li>• Coefficient of thermal expansion</li> <li>• Electric conductivity</li> </ul>

Relative Movability of coupling partners		
<b>Freedom</b>	<b>Connection Type</b>	
<ul style="list-style-type: none"> <li>• Glide</li> <li>• Role</li> <li>• Role with slip</li> <li>• Bore</li> </ul>	<ul style="list-style-type: none"> <li>• Form fit</li> <li>• Material bond</li> <li>• Frictional contact</li> </ul>	<ul style="list-style-type: none"> <li>• Mediate</li> <li>• Intermediate</li> </ul>
<b>Transmission Subject</b>	<b>Function</b>	
<ul style="list-style-type: none"> <li>• Energy</li> <li>• Material</li> <li>• Information</li> </ul>	<ul style="list-style-type: none"> <li>• Position</li> <li>• Connect</li> <li>• Guide</li> <li>• Support</li> <li>• Transmit</li> </ul>	
<b>Interface Type</b>	<b>Standardisation</b>	
<ul style="list-style-type: none"> <li>• Slot</li> <li>• Bus</li> <li>• Sectional</li> </ul>	<ul style="list-style-type: none"> <li>• None</li> <li>• Internal</li> <li>• External</li> </ul>	

### 3.2 Analysing interfaces with the contact and channel model

#### 3.2.1 The Contact and Channel Model

One way to visualise the relation between functions and physical parts is the *Contact and Channel Model (C&CM)*. It was created by *Matthiesen (2002)* and *Albers et al. (2006)*, and can mainly be described as a simplified representation of physical structures and their interacting surfaces.

*Feldhusen and Grote (2013)* provide a step-by-step procedure for using the *C&CM* for analysis and synthesis cases, as in *Lemburg (2009)*.

The *C&CM* consists of **Working Surface Pairs (WSP)** that enforce the physical interaction between **Working Surfaces (WS)**. These Working Surfaces are connected through **Channel and Support Structures (CSS)**. Additional elements in the model are **Limiting Structures (LS)**. Figure 7 shows an example of a C&CM for a portal crane, as in *Albers (2006)*. The crane consists of three main elements, two posts and a beam (CSS). The connections between them are the WSP that transmit forces that result from weight, and operation forces from the beam to the ground.

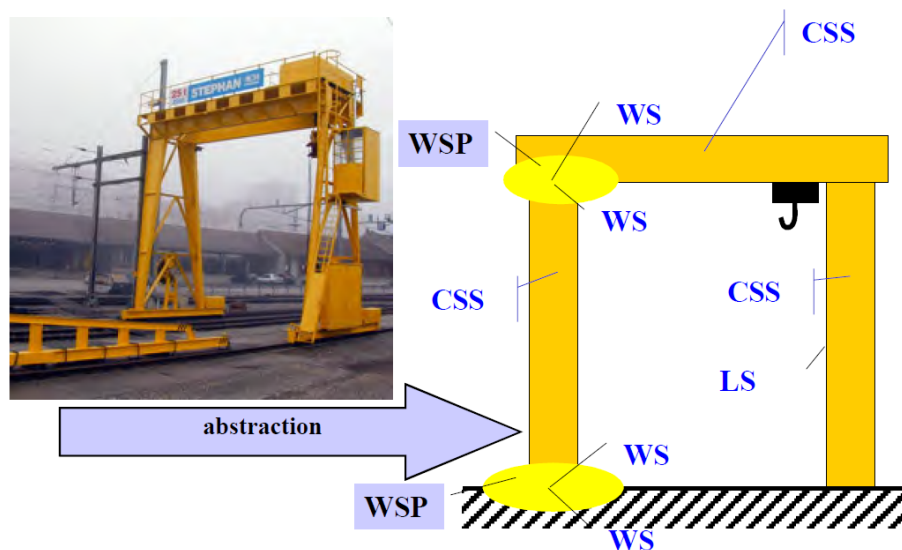

Figure 5. Contact and Channel Model illustrated using a portal crane, as in *Albers (2006)*

### 3.2.2 Adaption of the C&CM to Interfaces

To use the C&CM to investigate interfaces it has to be adapted to the needs of robust design. Generally, the model should contain every characteristic shown in Table 1. While geometric properties cannot be visualised in a comprehensive way, transmission subjects and the relative movability of the interfaces can be considered in the C&CM. The transmission subjects can be represented through the arrow notation proposed in Figure 6. To consider movability, the symbols for working principle sketches can be modified, as shown in Figure 8, to focus more on the WSPs. The symbols are based on notations in *Frei (2002)*.

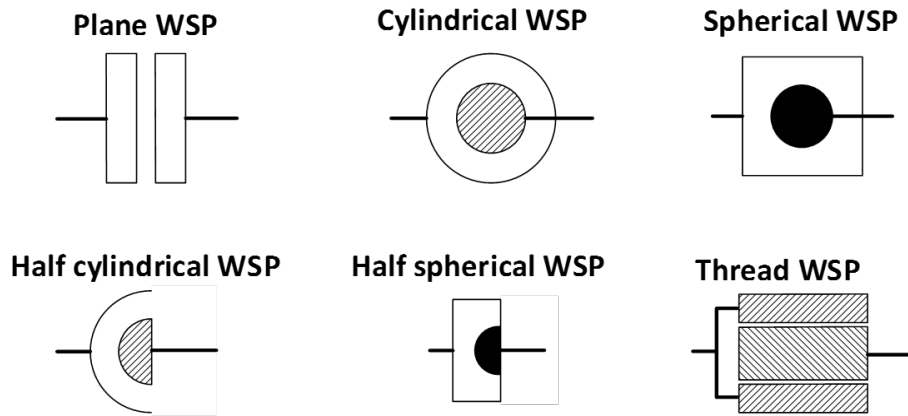

Figure 6. Representing WSPs in Working Principle sketches

Using these symbols in Working Principle Sketches allows the engineer to understand how parts and modules interact with each other, then find alternative solutions or understand the sensitivity of design parameters.

### 3.2.3 Example

The example structure is a simple tripod that transmits a force from an additional extra weight into the ground (Figure 9). It consists of three round pillars, a disk with a centred hole and the extra weight. The connection between the pillars and the disk is a cylindrical surface that centres the pillar in the hole, a surface working pair that transmits forces in a negative vertical direction via form closure and screw connection to lock the positive vertical direction and which elastically pretensions the interface. The C&CM Model is shown on the right side of Figure 9. The involved parts are abstracted as boxes, and their connection can be visualised using the symbols proposed for working surface pairs (WSP).

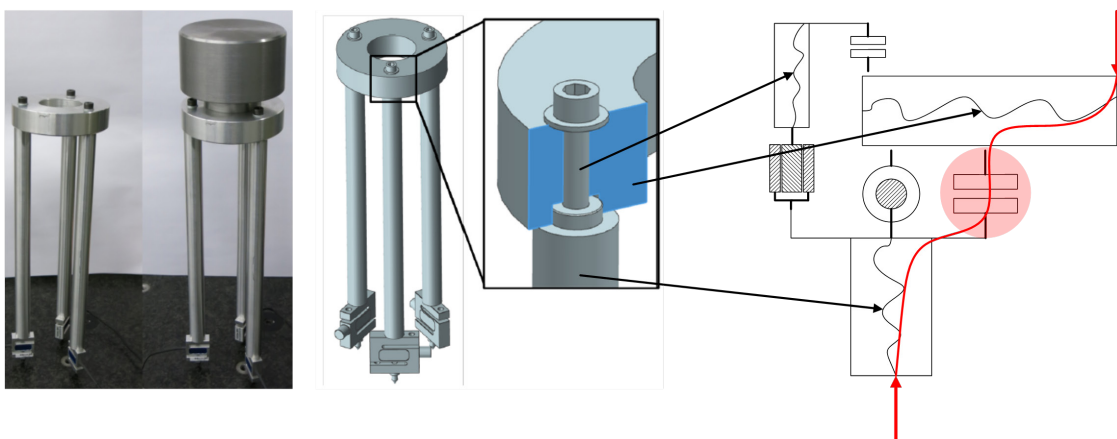

Figure 7. Tripod Example of the C&CM with focus on WSPs. The pictures on the left and in the middle are taken from *Eifler (2014)*.

To analyse the tripod system, C&CM representation can be used to identify important design parameters of the interface. It may be useful to mark energy, material and information flows to better understand the affiliation of parts and WSPs to particular functions. In the example, the plane/plane surface pair realises the function *guide force* from the disc to the pillar.



## 4 CONSIDERING UNCERTAINTY

As in the working hypothesis of the SFB 805 research centre, uncertainty occurs if process properties cannot be determined (*Hanselka and Platz (2012)*). To investigate uncertainty in interfaces, the characteristics of the interfaces introduced in Section 3.1 have to be related to the processes that cause the specific uncertainty.

If the transmission of energy, material and information is interpreted as a process without a transformation of properties (an ideal working transmission process is characterised by unchanging properties), and the physical interface (represented by the model introduced in Section 3.2) provides the working factor for the transmission process, the process and functional perspectives can be combined into one model, i.e. uncertainty and its influences on the characteristics of interfaces can be visualised. As in *Engelhardt (2013)*, this model makes it possible to identify uncertainty and uncertainty chains consistently. The whole lifecycle, from material processing to product disposal, (Figure 10) can now be modelled.

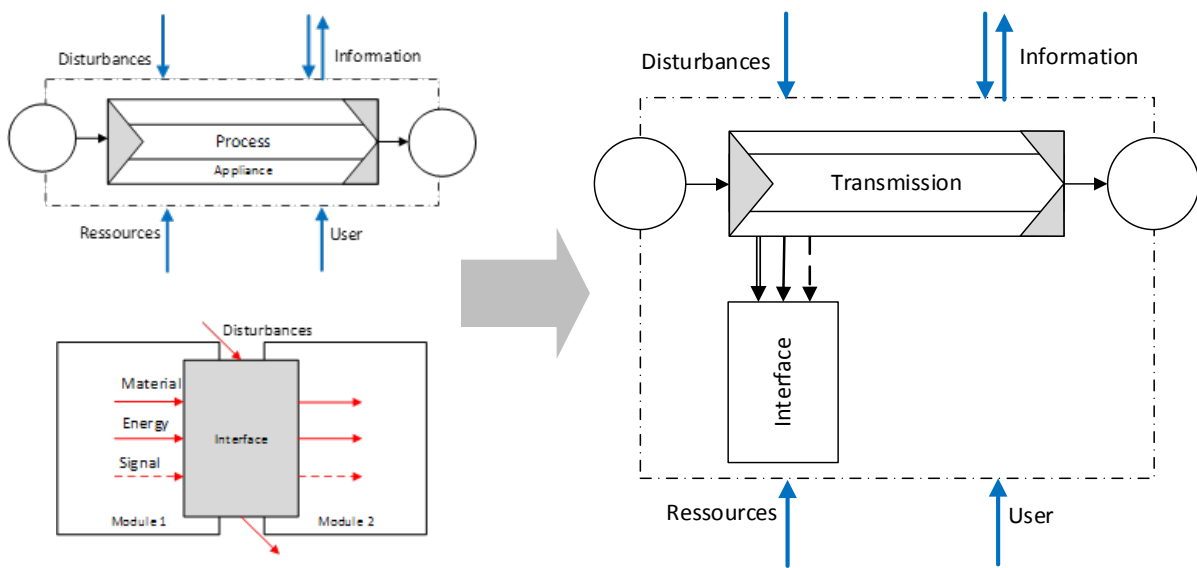

Figure 8. SFB 805 process model adapted to interface modelling.

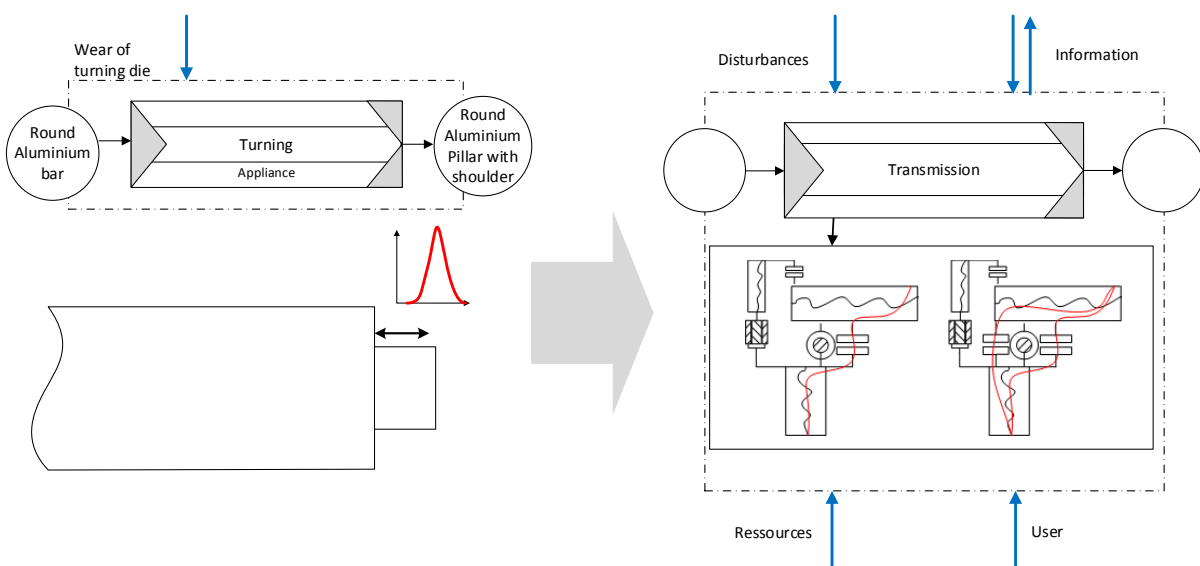

Figure 9. Example of the relationship between uncertainty in a turning process and its influences on the functionality of the resulting interface. The variation in shoulder length leads to an additional WSP, which destroys the clarity of the design.



This procedure allows the engineer to systematically model all phases of the product lifecycle and find relations between uncertain parameters. The information obtained in this way can be used to derive new solutions that are robust against the identified variations. In the example shown in Figure 11, wear of a turning die leads to change in the length of the shoulder of the tripod pillar. This deviation results in a non-deterministic description of the property length and can be represented using a C&CM (two extreme cases depicted in Figure 11 on the right side). In case two, the length of the shoulder leads to an additional WSP, and design clarity (*Feldhusen and Grote (2013)*) can no longer be assured. The process and the C&CM together allow the designer to recognise relations between design parameters, deviations and functions. Based on this knowledge, alternative solutions can be generated.

## 5 CONCLUSION AND OUTLOOK

A short introduction to uncertainty and uncertainty terms for modular systems was provided: *Interface uncertainty and Configuration uncertainty*. To control these forms of uncertainty, a particularly robust design methodology is needed. It should consist of models, methods and tools to describe, analyse, assess and control uncertainty. This paper contributes to the models available. First, a generalizable definition of interfaces is derived from literature. Fortunately, the existing definitions can be combined. To achieve this, the expression *elementary interface* is introduced. Every interface can now consistently be described through the sum of its elementary interfaces and the surrounding working structures. The properties and functions that characterise interfaces found in literature were listed in a table, which can be used by designers as a checklist during the design process. The idea is to help designers combine interface characteristics with lifecycle information. To support this visually, the C&CM was identified as useful support when analysing product structures with a focus on elementary interfaces. To represent these elementary interfaces, six generic Working Surface Pair Symbols were derived. This measure enriches the existing C&CM with more detailed information and helps to combine the interface characteristics with the WSPs in the C&CM.

In Section 4, uncertain processes and interfaces were brought together into one model that can now be used to consistently describe uncertainty across the entire product lifecycle. This model requires a slightly different understanding of processes because it does not match the actual definition of changed properties. Nevertheless, a transmission is still seen as a process because of its time dependency and flows.

Further work should produce design guidelines that can be used to transform information on interfaces and uncertain processes into a more robust product. A measure to systematically support the identification of relevant design parameters should be developed. This can be done by combining a process database with interface characteristics to find properties that are affected by process deviations.

The final goal should be the implementation of a methodology that can be used as early as possible in the design process to reduce iterations and save money.

The results should be further evaluated using industry case studies to demonstrate their applicability to real design tasks, with their additional challenges, such as acceptance and usability.

## ACKNOWLEDGEMENT

Collaborative Research Centre SFB 805 “Control of uncertainty in load-carrying mechanical systems” achieved the results presented here in subproject “A2: Robust Design – Methodology for the Design of Systems with Optimum Uncertainty Solutions”. Thank you to the Deutsche Forschungsgemeinschaft (DFG) for funding and supporting SFB 805.

## REFERENCES

- Albers, A., Ohmer, M., Eckert, C. (2006) Engineering Design in a different way: Cognitive Perspective on the Contact & Channel Model Approach, Visual and Spatial Reasoning in Design III, University of Sydney, 2006, Gero, J.S, Tversky, B., Knight, T., pp. (3-21).
- Birkhofer, H. (1980) Analyse und Synthese der Funktionen technischer Produkte, Braunschweig/ Fakultät für Maschinenbau und Elektrotechnik der Technischen Universität Carolo- Wilhelmina zu Braunschweig.
- Braha, D., Minai, Al. A., Bar-Yam, Y. (2006) Complex Engineered Systems: Science Meets Technology (Understanding Complex Systems). Springer-Verlag New York, Inc., Secaucus, NJ, USA.

- Ebro, M., Howard, T. J., Rasmussen, J. J. (2012), The foundation for Robust Design: Enabling Robustness through Kinematic Design and Design Clarity, INTERNATIONAL DESIGN CONFERENCE - DESIGN 2012, volume 2, pp. (817)
- Eifler, T. (Handed in 2014) Modellgestützte Methodik zur systematischen Analyse von Unsicherheit im Lebenslauf technischer Systeme, Darmstadt/ Technische Universität Darmstadt.
- Eifler, T., et al. (2011) Approach for a consistent description of uncertainty in process chains of load carrying mechanical systems, ICUME 2011, volume 104, pp. (133).
- Engelhardt, R. A. (2013) Uncertainty Mode and Effects Analysis – heuristische Methodik zur Analyse und Beurteilung von Unsicherheiten in technischen Systemen des Maschinenbaus, Darmstadt/ Technische Universität Darmstadt.
- Ersoy, M. (1975) Wirkfläche und Wirkraum – Ausgangselemente zum Ermitteln der Gestalt beim rechnergestützten Konstruieren, Braunschweig/ Fakultät für Maschinenbau und Elektrotechnik der Technischen Universität Carolo- Wilhelmina zu Braunschweig.
- Feldhusen, J., Grote, K.-H. et al. (2013) Pahl/ Beitz Konstruktionslehre. Berlin: Springer.
- Frei, N. (2002) Der Konstruktionsprozess: Wirkmodelle basierend auf Constraints, Zürich/ Eidgenössische technische Hochschule Zürich.
- Garud, R., Kumaraswamy, A. (1996), Technological designs for retention and reuse. Jnt. J. Technology Management, Special Issue on Unlearning and Learning for Technological Innovation, Vol. 11, Nos. 7/8, pp. (883-891).
- Gramlich, S. (2013) Vom fertigungsgerechten Konstruieren zum produktionsintegrierenden Entwickeln, Darmstadt/ Technische Universität Darmstadt.
- Hanselka, H., Platz, R. (2012) Controlling Uncertainties in Load Carrying Systems. Konstruktion, No. 11/12 – 2010, pp. (55 – 62).
- Matthiesen S. (2002) a contribution to the basis definition of the element model “Working Surface Pairs & Channel and Support Structures” about the correlation between layout and function of technical systems, Karlsruhe/ Universität Karlsruhe.
- Roth, K., 1982, Konstruieren mit Konstruktionskatalogen, Heidelberg, Springer Verlag.
- Ulrich, K. (1995) The Role of Product Architecture in the Manufacturing Firm. Research Policy, Vol. 24, No.3/95, pp. (419-440).
- Schilling, M.A. 2000. Towards a general modular systems theory and its application to inter-firm product modularity. Academy of Management Review, Volume 25, pp. (312-334).
- Stone, R. B., Wood, K. L., Crawford, R. H.(2000), A heuristic method for identifying modules for product architectures, Design Studies January 2000, Volume 21, Issue 1, pp. (5–31).