



## EVOLUTION OF ROTOR SPIDER DESIGN FOR VERTICAL HYDRO-GENERATORS

M. Vukšić, I. Triplat and D. Marjanović

*Keywords: hydro-generator, rotor spider, design improvement*

### 1. Introduction

When it comes to innovation of mechanical design, large electric machines industry is considered one of the most “traditional”. This can be seen just by looking outline drawings of modern machines and machines produced some half century ago, and even non-expert engineer will notice that they are quite similar. There are multiple reasons for this. One of the most important is tendency to use proven designs, since these machines are very expensive, and one major design failure is enough to cause serious problems to the producing company. Other reason is that machine operators want design that they are familiar with. Field where most innovations are made is electrical design, in which with use of modern insulation materials we can achieve significant increase of efficiency of machine at minimum cost. According to IEC 60085, allowed temperature of stator winding, which is key parameter for electrical design of generator, has changed from class B in 1950's to class F [IEC 2007] in present day has allowed power increase of 20-40% just by changing insulation material. Still, in recent years there is significant increase in number of mechanical design innovations due to the fact that price of material and energy needed for production is increasing, and ever-shorter design and production periods give this previously neglected field much more attention.

In this article, a proposal for a novel design of rotor spider will be presented. Significance of this paper is not just as example of design optimisation, but also in term of type of industry it belongs. Prototype according to presented design will be produced, and it will also be first product in series of three, as due to size and costs, small batch industry does not allow discarding prototypes. Limitations and benefits of proposed design will be compared with existing designs. Basics of spider analysis will be given with constraints and requirements that led to a new design. Recommendations for further development are given in the conclusion.

Rotor spider is part of vertical hydro-generator which transfers torque and rotation from shaft to rotor rim and poles [Wiedemann et al. 1967]. Poles create rotary magnetic field which induces electricity in stator winding, and thus alternated current is produced. Depending on size and design it is usually used on medium and low speed generators. Generally, it is consisted of hub with upper and lower flange, radial ribs, star shaped rings and vertical beams used for connection of rotor rim. Spider is connected to shaft(s) via flange connection with bolts or pressure fit with additionally at least one key. Rotor rim is connected to spider with tangential wedges and in some cases with additional pressure fit. Other usual parts that are connected to rotor spider are fans and brake ring.

Design of rotor spider varies depending on generator outline, number of poles and size. On Figure 1 is shown most common layout of the medium sized generator.

Until electrical welding has become common in the second part of the 20th century rotor spiders were made from cast iron in sand moulds. Contemporary rotor spiders are designed as welded structures from high quality hot rolled steel sheets, welded with specially controlled welds.

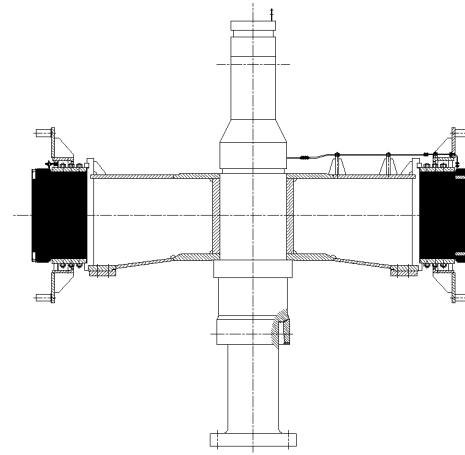
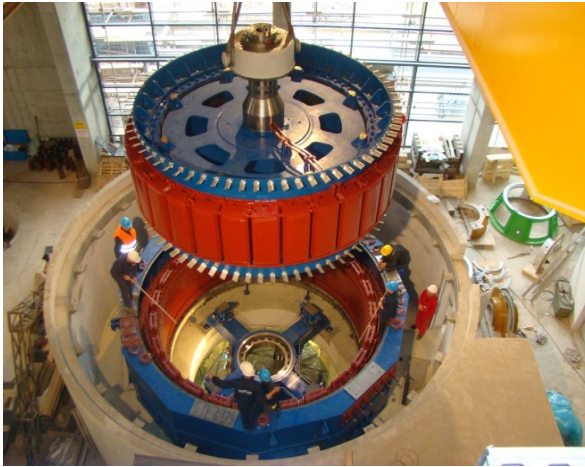

**Figure 1. Usual layout of generator rotor with shaft, rotor spider, rotor rim brake ring and fans**

## **2. Loads and calculation method**

Loads exerted on rotor spider can be divided in two groups based on situations in which they occur [Detinko 1969]:

1. Nominal loads:
  - Torque due to nominal operation
  - Weight of rotor spider, rim, poles, fans and brake ring
  - Centrifugal force due to rotation
  
2. Transient loads
  - Runaway
  - False synchronisation
  - Two phase short circuit
  - Three phase short circuit
  - 50% of poles in short circuit
  - Jacking of rotor

Nominal loads occur always during generator lifespan. For each of the scenario number of occurrences is prescribed during generator lifetime, these numbers are unique for each power plant. Lifespan of generator varies in generally from 30-50 years depending on working cycle parameters.

Aside from nominal load case, worst case scenarios from the transient loads spectrum are chosen. Selection depends upon electrical calculation and turbine type. Allowable stresses and safety factors are prescribed by customer in tender, but generally most common stress factors are 3 for nominal conditions and 1.5 for transient conditions. All safety factors given here define safety factor against yield point of material.

In the past, traditional analytical methods were used for calculations. This way, characteristic places which are likely to have highest stresses are identified and tested. These methods give little space for improvement due to limited accuracy, complex shape of rotor spider and amount of time needed for each iteration in calculation and redesign. Nowadays, finite elements method allows mechanical designers to vary the design in matter of hours, and using number of built in tools in software packages to achieve improved design. One of the most used methods is optimization with concern to mass which is also used in case study presented in this paper.

Vibration analysis was also performed to ensure that there are no resonances close to working regimes of machine.

### 3. Case study

Given example for this paper is rotor spider for umbrella type generator (IM 8140 layout according to IEC 60034-7) [IEC 1992] with maximum power of 23.8 MW and 107 rpm. Outer diameter of rotor spider is 5188 mm. This generator is designed for Brežice hydro power plant in Slovenia. Umbrella type generator is specific because turbine bearings support generator and generator uses the same shaft with turbine.

Improved design of rotor spider will be compared to earlier designs from previous similar projects with classical rotor spider layout. This comparison has to be qualitative due to the fact that each of those projects was unique.

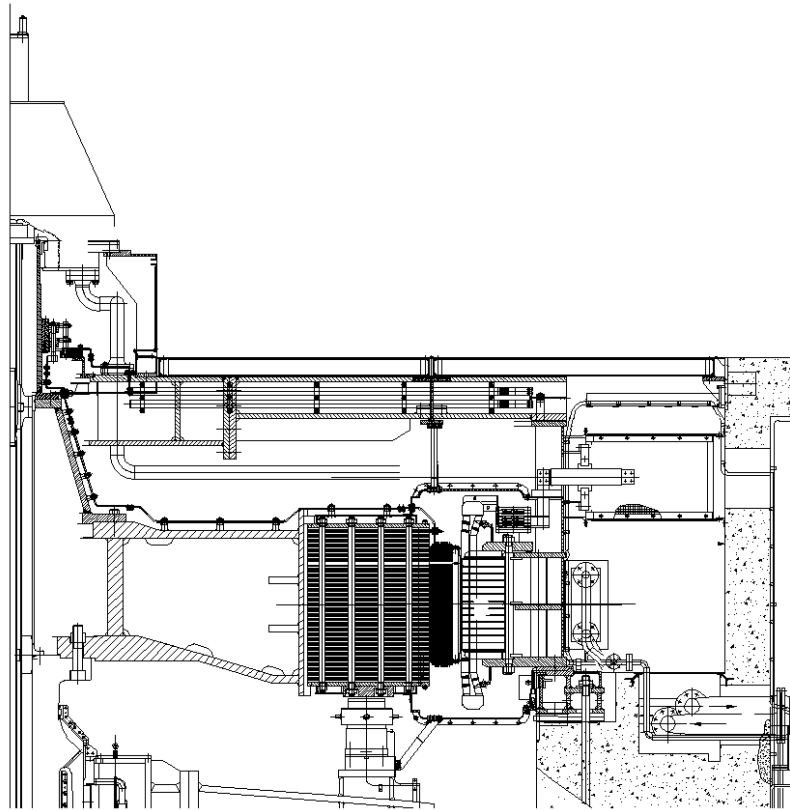

Figure 2. Example of umbrella type generator shown as  $\frac{1}{2}$  cross section

### 4. Design review

#### 4.1 Design limitations

Design of turbine shaft flange: this input is supplied by turbine supplier, and defines thickness of lower flange, and method of coupling. It also has direct influence on hub dimensions and positioning.

Layout of rotor rim correlates number of beams for tangential wedge support with number of poles. Since case study generator has 56 poles and overlap of sheets is  $\frac{1}{4}$ , number of wedge support beams is 14. Height of wedge beam is defined by electrical calculation of generator and flywheel effect specification.

Other design parameters are defined by generator outline drawing, which defines in what way generator interacts with its surroundings e.g. foundation in powerhouse, coupling with turbine, connections with cooling system etc. However, they can be changed in reasonable manner if needed.

Thicknesses of plates, dimensions of support ribs and dimensions of fillets etc. are subject to comply with mechanical calculations, and minimum technological parameters defined by production process,

e.g. even if calculation result shows that sufficient plate thickness is 5mm, minimum thickness of 15mm will be used due to annealing process requirements [Walker 1981].

## 4.2 Description of design process

Design process wasn't something that was planned and prepared using any of the common design planning methods. Idea itself came after reviewing somewhat similar design's mechanical calculation, where conclusion was made that it is over-dimensioned in term of mechanical strength, but cannot be altered due to other limitations stated in section 4.1.

Main idea was to reduce number of radial ribs while sustaining number of vertical beams. If any increase of strength should be necessary it would have been done by re-shaping of observed part instead of increasing mass (thickness).

As it is earlier mentioned, no particular design process was intended, however, it can be described as convergence iteration with brainstorming between steps [Cross 2008]. First iteration of design was classical design shown on Figure 3. After that 3D model was altered several times while experimenting with oblique elements, slanted ribs, and different forms of star sing. After each iteration, re-evaluation was made, and strengths and weaknesses of it were noted. Gradually, design which is described in detail in next section has emerged.

Some solutions from previous paragraph were discarded as un-necessary, however they should be taken into account while designing rotor spider for larger generator, as they may prove valuable there.

## 4.3 Description of improved design and comparison to normal

### 4.3.1 Inner part (Hub, upper and lower flange)

Upper and lower flange depend on, as stated before, on turbine flange design and upper connecting parts. Only difference between lower flange on improved and normal design is absence of gradual transition from flange to star ring. Numerical simulations show that sloped transition doesn't reduce stress concentration in such manner that it would be justified to add more material.

Hubs are normally made from bent thick plate which is then welded or forged if bending is not possible. Each of these solutions are not particularly cost efficient. Instead of that, for hub material, hot rolled thick seamless pipe, reinforced with vertical ribs is used. This solution is more economical due to same stiffness with smaller mass.

### 4.3.2 Outer part (Ribs, star ring, beams, bearing ring and support)

Due to the fact that 14 beams are needed as described in paragraph 4.1, normal design states that there should be 14 main ribs. On the other hand, mechanical calculation states that 14 ribs aren't necessary. If every second rib is left out, significant saving of material can be utilized. Problem with this layout is that unequal displacements occur on the beams that are connected to ribs and on those that aren't. This problem becomes significant at runaway condition. Solution to this problem states that it is better to have design with a bit less radial stiffness than stiffer design with unequal deformations [Muszynska 2005]. Seven ribs were chosen, and positioning of beams was turned for  $\frac{1}{4}$  of angle between two ribs. Holes on ribs were added for additional weight reduction.

To ensure adequate support for beams small ribs were added to connect them with sheet rim. On parts where there is no main rib holes were cut for purpose of rotor rim stacking, they also ensure some additional weight reduction. Sheet rim also provides better support for brake ring bracket while jacking rotor.

Upper star ring was added with outer rim to ensure more equal transfer of torque from rotor rim to hub. Since there is brake ring on the lower side, its support performs same task.

The Figure 3 illustrates the new, improved (a) 3D model of rotor spider compared with the previous, similar design (b). In the new design number of components in assembly is significantly reduced. Due to this and thinner plates used the total weight has been reduced. Mechanical calculations show that even thinner sheet could be used but due to technological reasons and parameters of welding minimum thickness of 15mm was used. Improved design weights 12.5t and normal design 24.8t, which is total weight reduction for 49.5%.

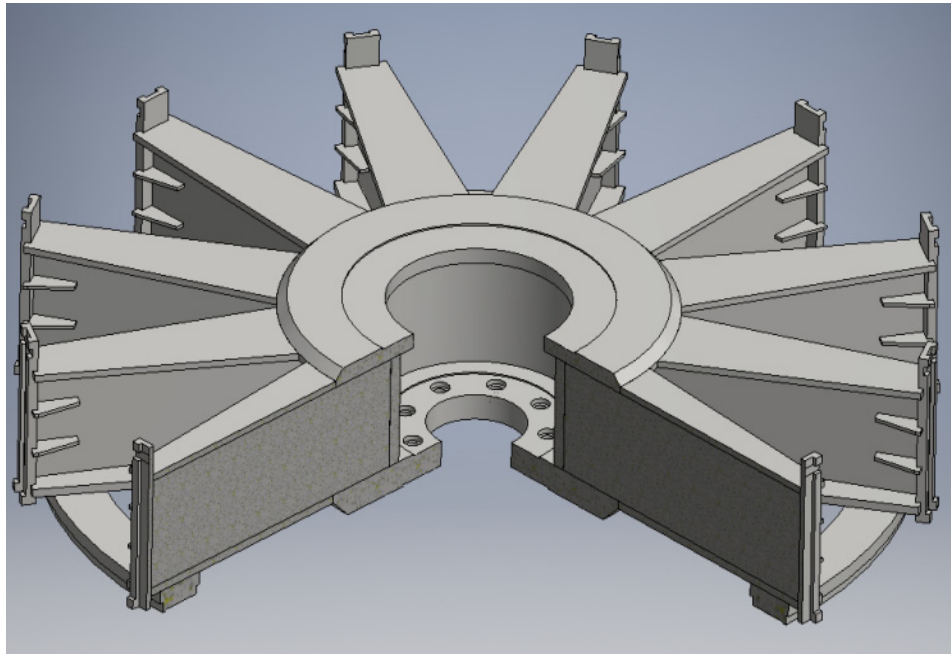

(a)

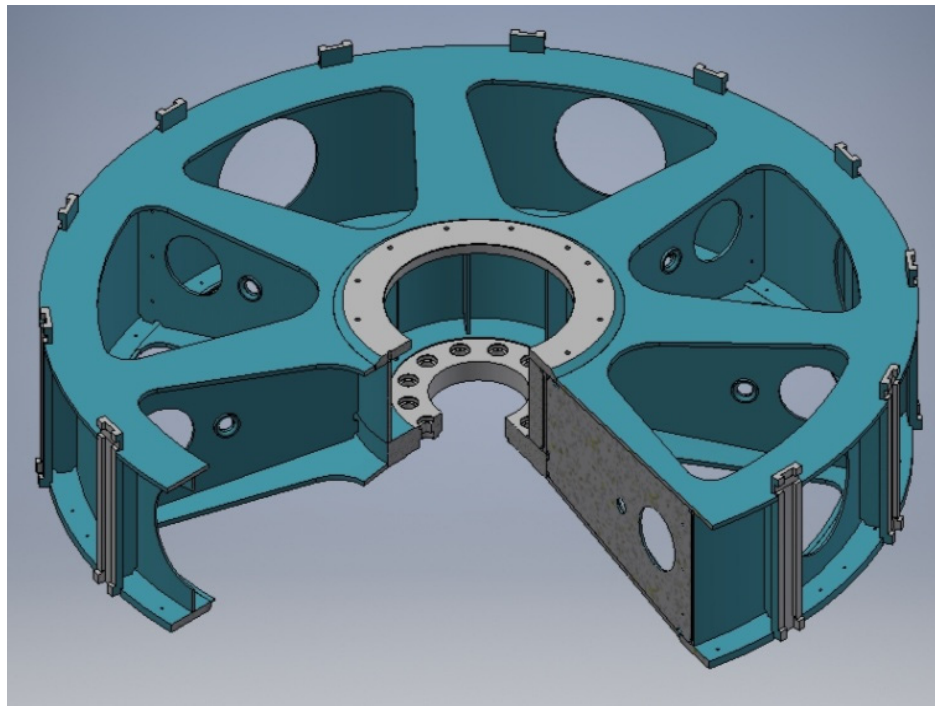

(b)

**Figure 3. Improved (b) and normal (a) 3D model of rotor spider**

#### **4.4 Validation of design**

It is very hard to compare solutions of similar designs since each has its own specifics as generators on which they are used. First idea was to simply divide mass of rotor with power of generator. However while experimenting with numbers this proved to be insufficient and that more factors should be taken

into account. In order to give at least qualitative comparison here is shown effectiveness of design ratio. It is calculated with formula:

$$ED = \frac{Mass}{0.5 \cdot Power \cdot 0.3 \cdot mD^2 \cdot 0.2 \cdot Diameter} \quad (1)$$

Where coefficients 0.5, 0.3 and 0.2 represent influence of main factors:

- Power -Mechanical power [MW] is the most important factor as two generators of the same size can have different power due to electrical design.
- $mD^2$  - Flywheel effect of generator is determined by turbine type and design.
- Diameter – Diameter of rotor spider.

Depending on outline of generator, different size of rotor spider can be used by varying inner diameter of rotor rim. These values are derived from experience and references from earlier projects. Their values were derived from query which was made in design office where authors work. Even though representative specimen is relatively small, it consists exclusively of experienced mechanical designers who have designed number of rotors and whole generators. Unfortunately this query could not be extended to other producing companies, since rotor design is mostly patented and presumably they would be unwilling to cooperate with employees from competition company.

In Table 1 we have data from earlier projects. Projects marked with (\*) are not same layout as others due to the fact that in that era umbrella type generators didn't exist. They are chosen as reference since they were made with cast iron rotor spider and have similar parameters. All stated references are from portfolio of author's company as data from other companies is not available to public.

**Table 1. List of references and effectiveness of design ratio (EDR)**

Year	Power plant	Country	Power [MW]	Mass [kg]	Diameter [m]	$mD^2$ [tm <sup>2</sup> ]	Effectiveness of design ratio
1926	Imatra (*)	Finland	26.6	31400	5.79	800	8.49
1956	Svarthalsforsen (*)	Sweden	32.2	25200	5.82	1418	3.16
1961	Potpeć	Serbia	22.2	12800	4.29	1300	3.45
1987	Mostar	BIH	33.3	21200	4.45	2100	2.27
2000	Plave 2	Slovenia	25.5	17500	3.95	2900	2.00
2002	Vuhred-Ožbalt	Slovenia	33.3	26800	2.51	4100	2.61
2007	Blanca	Slovenia	18.3	24800	5.5	2800	2.93
2016	Brežice	Slovenia	23.8	12500	5.19	2800	1.20

Intention of this paper was not to compose new way of validating mechanical design. EDR was designed especially for this topic and similar size of generators. While experimenting with values it was noted that EDR gives correct tendency in interval of power roughly from 15-40 MW. Its sole purpose is to show tendency of rotor spider design effectiveness and to compare new improved design with old ones. Graphical representation of this claim can be seen of Figure 4, from which we can see that until 1950's and wide spread use of welding machine, cast iron designs have greatly improved due to invention of new calculation and testing methods. From 1950's ratio remains almost the same due to the fact that no greater progress in calculation methods was made until 2000's when widespread use of numerical methods started.

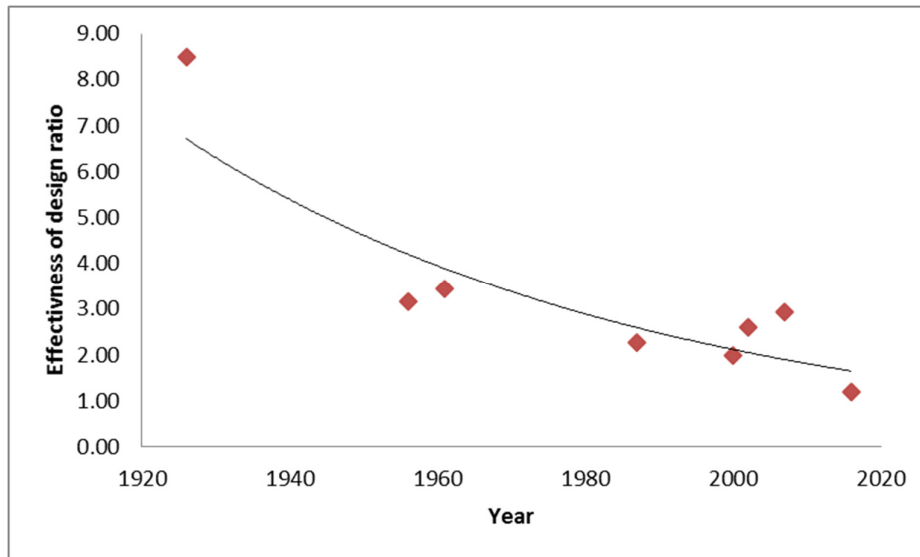

Figure 4. EDR trough years (red) and tendency (black)

## 5. Conclusion and recommendations for further work

As it can be seen from the results, new design of rotor spider presents milestone in design. Not only that direct economic benefit is around 50%, but also simpler design with thinner sheets and fewer welds gives quicker production time. This type of design can also be used also on larger generators of the same type where its benefits would be even more noted due to fact that then minimum thickness sheets could be used since they will be thicker than those in case study. This type of innovation can be applied for international patent, and thus give extra credit both in economical (marketing) manner, and off course also in field of mechanical design for producing company

Even though this saving on mass is relatively small comparing to mass of entire generator it is around 3% in mass and about 1.5% in price it can be decisive factor that can enable winning of tender. Also, this “out of box” way of thinking can set path for different approach in design of the other welded structures in generator and produce more time and money savings.

In recent years designers are making a lot of effort to come up with new design layouts due to fast advance in CAD/CAM technology, therefore new ways of design that were not common for this type of industry should be tested. Major problem in this type of industry is that there is no prototype. First unit delivered must be fully operational and will be reworked until it meets all requirements of its tender specification. Therefore great attention should be given to every aspect of possible innovation drawbacks. This can be done with use of simulation and virtual prototyping software. Use of oblique elements (triangular and diamond shapes), truss-plate structures etc. should be taken into account. Also, advanced methods of optimization such as genetic algorithms, topological optimisation etc. should be used to even more improve existing designs. New methods of simulations from electrical design, vibrations, assembly simulations to cooling and ventilation should be also investigated.

Even though most of methods described are already used in other industries, their use in single batch and small series production should be further investigated, not only for electrical machines production but also for turbines and other large facilities. Reason for this is that critical factors for these machines have already reached limits of current scientific background, and these before considered “second grade” factors are now starting to be decisive edge in success of project.

## References

- Alfirević, I., "Nauka o čvrstoći I", Golden marketing – Tehnička knjiga, Zagreb, Croatia, 1999.  
 Collins, J. A., "Failure of materials in mechanical design - analysis prediction, prevention", Wiley-Interscience Publication, John Wiley & Sons, UK, 1981.  
 Cross, N., "Engineering Design Methods: Strategies for Product Design", 4th Edition, Wiley, USA, 2008.

*Detinko, F. M., "Strength and vibrations of electric machines - Russian Edition", USSR, 1969.*  
*Gustavsson, R., "Modelling and Analysis of Hydropower Generator Rotors", Luleå University of Technology, The Polhem Laboratory, Division of Computer Aided Desing, Sweden, 2005.*  
*IEC, "IEC 60034-7", International Electrotechnical Commission, UK, 1992.*  
*IEC, "IEC 60085-2007", International Electrotechnical Commission, UK, 2007.*  
*Muszynska, A., "Rotordynamics", Taylor & Francis group, UK, 2005.*  
*Sorić, J., "Metoda konačnih elemenata", Golden makreting – Tehnička knjiga, Zagreb, Croatia, 2004.*  
*Walker, J. H., "Large synchronous machines", Clarendon press, UK, 1981.*  
*Wiedemann, E., Kellenberger, W., "Konstruktion elektrischer Maschinen", Springer-Verlag, DE, 1967.*

Mario Vukšić, M.Eng.  
Končar - Generators and motors Inc., Design office  
Fallerovo šetalište 22, 10000 Zagreb, Croatia  
Email: mvuksic@koncar-gim.hr